

## Bauder Bitumen Refurbishment Warm Roof Outlet DN 90

V3 17.11.2022

### Product description

A thermally insulated cast polyurethane rainwater outlet with vertical spigot giving thermal continuity. The outlet comes with a pre-attached bituminous flange to ensure waterproofing integrity between the outlet and membranes. Outlet has a flow rate of 5.7 litres/sec based upon requirements of BS EN 12056:3:2000.

### Application fields

For use with Bauder bituminous waterproofing membranes when connecting into conventional gravity drainage systems. The product is designed to be used in warm roof scenarios. The spigot when fitted into an existing outlet using the 'push fit' seal, will accommodate internal diameters ranging from 98 to 107mm.



### Article Number

Bitumen Refurbishment Warm Roof Outlet DN 90 GB60264090  
Bitumen Refurbishment Outlet Housing GB60266090

Characteristic	Unit	Value
Length of outlet including spigot	mm	550
Width of outlet opening	mm	146
Width of spigot (external)	mm	87
Width of spigot opening	mm	82
Width of outlet body	mm	320
Width of bituminous flange	mm	495
Length of bituminous flange	mm	495
Flange surface finish (bottom)	-	fleece
Flange surface finish (top)	-	bitumen with a polyethylene film
Weight	kg	3.1
Flow rate performance	litres/sec	5.7*

\*Flow rate performance data using a 35mm head of water (including leaf grille), based upon requirements of BS EN 12056:3:2000. Further flow rate performance data can be obtained within this document. For bespoke drainage calculation performance data, please contact Bauder Limited.

### Storage guidance

Store under cover. Outlet bituminous flanges that have become wet must be allowed to fully dry out naturally before use. The leaf grille will be supplied with the outlet itself. Please see detail drawing below.

### Packaging material

The outlet will be delivered in a cardboard box (readily recyclable). Also, within the cardboard box will be the leaf guard and seal which will come packaged within a low-density polyethylene bag (readily recyclable), which weighs 29 grams.

### Handling/PPE

All persons using the product should be fully aware of the manual handling methods as roofing materials are heavy and can cause serious injury. When using the product, installers should be provided with, and wear, suitable personal protective equipment.

### Disposal guidance

Disposing of any waste material must be carried out in accordance with national regulations.

### Further information/ documents

Current documents such as brochures, installation guides, etc. can be found by visiting [www.bauder.co.uk](http://www.bauder.co.uk)

### International Standards Organisation (ISO)

**ISO 9001:2015 Quality Management**  
Certificates EN1271 (UK)

**ISO 14001:2015 Environmental Management Certificates**  
A10552 (UK)

# Technical data sheet

Dimensions:

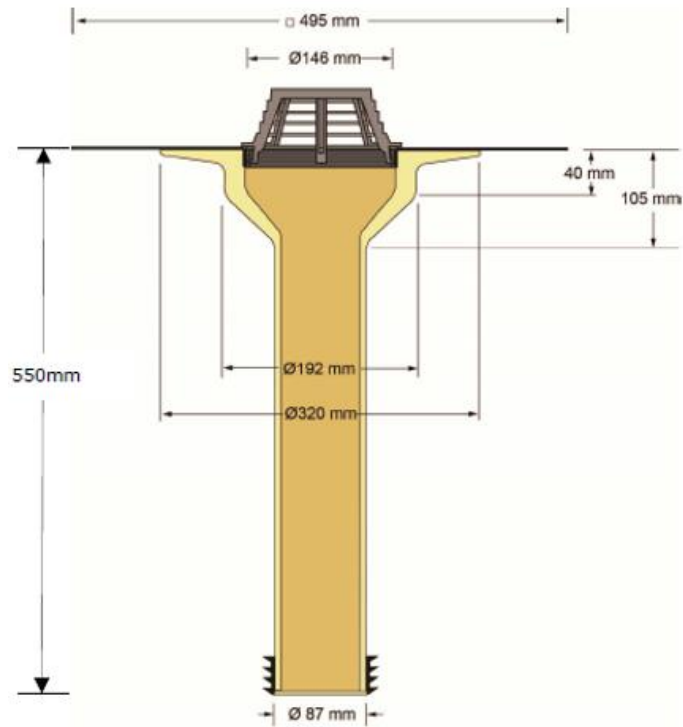

Detail drawings:

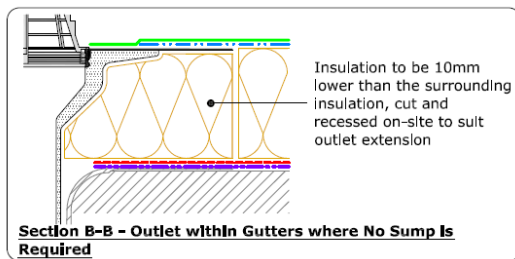
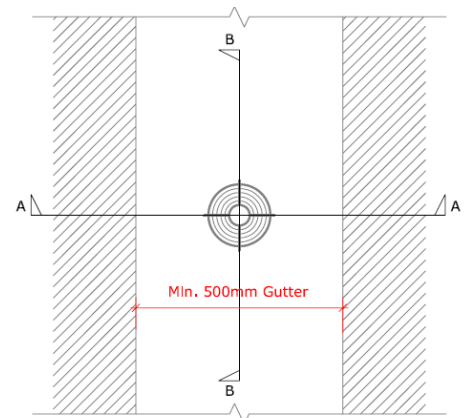
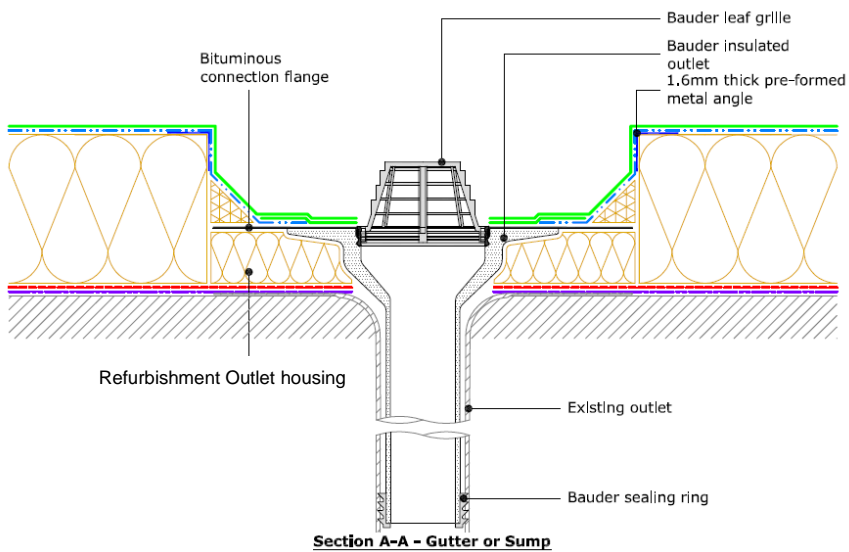

# Technical data sheet



## Refurbishment Outlet Housing

Pre-formed to aid installation of the Refurbishment Outlet

Dimensions 500 x 500 x 60mm

Thermal conductivity – Lambda value 0.025 W/mK

**Installation Guidance and data:** Please refer to the Bauder Installation Guide and project specification for guidance.

It is important that any replacement outlet does not reduce the overall drainage capacity of the roof. Therefore, the flow rate performance of the replacement outlet must be at least equal to or better than the existing units to provide full drainage functionality, but it is less likely to be better.

When installing this product through an existing rainwater outlet, the bowl diameter of the existing unit affects the minimum thickness required, as the lower part of the bowl is tapered and sits within the recess created by the bowl of the existing unit. To calculate the minimum thickness required, use the table below to find the corresponding bowl diameter and related minimum thickness of insulation.

Existing Bowl Diameter	Minimum Insulation Thickness
100mm	92mm
105mm	90mm
110mm	87mm
115mm	85mm
120mm	83mm
125mm	81mm
130mm	78mm
135mm	76mm
140mm	74mm
145mm	71mm
150mm	69mm
155mm	67mm
160mm	64mm
165mm	62mm
170mm	60mm
175mm	57mm
180mm	55mm
185mm	53mm

## Fixing:

When retaining the existing outlet, it is important that the waterproof seal on the end of the outlet spigot of the Bauder Refurbishment Warm Roof Outlet passes beyond the existing outlet and seals to the pipework below it. The length of spigot required to achieve this should be determined and then the spigot cut to the required length with an appropriate saw.

The refurbishment outlet housing can be used to accommodate the shape of the outlet bowl, so that the unit sits flush with the board surface.

Prior to installation, the existing downpipe should be cleaned to remove any dirt or debris that might otherwise affect the quality of the seal between the new outlet and existing pipe.

The flexible seal should then be attached to the end of the spigot and then the unit inserted down through the existing outlet to make contact with the existing downpipe beyond.

When the existing pipework is in the range of 98 to 107mm, the top of the flexible seal (wider flanges) can be cut off to allow the seal to fit within the smaller pipework.

In all cases, during installation, the outlet must be mechanically fixed to the deck.

**Pipe connection:** Bauder Bitumen Refurbishment Warm Roof Outlets are suitable for connection to:

- uPVC "O" ring socketed soil grade pipe to BS 4514: 1983
- Socketed and socket-less cast-iron pipework to BS 416:1973 and EN 887. Socketed pipework will require cold caulking or PVC to cast iron adaptors. Socket-less pipework can be connection using an appropriate SML mechanical coupling.
- HDPE pipework with appropriate SML mechanical coupling

**Connectivity to below deck drainage pipework to be the responsibility of the plumbing contractor/drainage engineer.**

# Technical data sheet

## Drainage performance of the Bitumen Refurbishment Warm Roof Outlet DN 90:

The figures below are based upon the requirements of BS EN 12056: 3: 2000 and performances are given within 1/3 rainwater pipe capacity limits as required by BS EN 12056.

Flow rates are typically taken using a 35 mm head of water (including leaf grille), which for the Bitumen Refurbishment Warm Roof Outlet DN 90 gives a flow rate performance of 6.1 litres/sec.

		Head of water (mm)									
Size	5	10	15	20	25	30	35	40	45	50	55
90	05	1.3	2.1	3.1	4.0	4.9	5.7	6.7	7.7	7.9	8.2

## When designing a rainwater scheme, the following considerations should apply:

Always make provision for an additional back-up outlet to ensure that the roof will continue to drain in the event of a blockage, even if a single outlet is deemed to have sufficient flow to drain the area concerned.

Allow a safety factor of 10% above the published maximum outlet capacity to take account of greater than designed storm intensities.

Check that all outlets are correctly installed before completion or handover.

Check that all pipe connections are secure and that the leaf grilles are fitted.

All rainwater outlets should be inspected twice yearly for blockages and to clean out the outlets and remove any debris or leaf litter as part of the routine maintenance schedule.

**Safety Data Sheets are designed to provide the necessary information to recipients of substances and mixtures in the EU & UK. This product is classed as an article; therefore, this product does not have a requirement for a Safety Data Sheet.**