

# Fire Safety: Approved Document B 2019 with Amendments Issued

A review by Bauder Ltd



**UPDATED FOR  
2022 CHANGES**

The Building Regulations 2010

**Fire safety**

**APPROVED DOCUMENT**

**B**

## **Volume 1: Dwellings**

Requirement B1: Means of warning and escape  
Requirement B2: Internal fire spread (linings)  
Requirement B3: Internal fire spread (structure)  
Requirement B4: External fire spread  
Requirement B5: Access and facilities for the fire service  
Regulations: 6(3), 7(2) and 38

2019 edition incorporating 2020 and 2022  
amendments – for use in England

# Approved Document B - June 2022 amendments

## EXECUTIVE SUMMARY

Since the tragedy of the Grenfell fire there has been much more design focus on fire safety for membrane roofs, this document gives background to the European fire standards, the actual testing and key areas of concern set against the Building Regulations and the Approved Document B latest guidance amended in June 2022, that came into effect from December 2022.

## CONTENTS

	PAGE
Overview	3
European Fire Standards	3
Green Roofs	4
Roof Insulation Fire Performance	5
Compartmentation – junction of compartment wall with roof	5
New requirement of Approved Document B – External Walls and 'Specified Attachment'	7
Bauder Waterproofing Systems	8
Summary	9

# Approved Document B - June 2022 amendments

On the 30th August 2019, based upon the changes to the Building Regulations, the new edition of 'Fire Safety- Approved Document B' (AD B) came into force affecting flat roofing. Gone is reference to the National Classification system set out in BS 476-3:2004 as the principal determinant of external fire performance for roofs (with exception of a listing in Appendix B Table B2 that sets out the old classification system for historic projects).

This means that the European Classification system set out in BS EN 13501-5, that has run alongside the National Classification system for many years, is now the main reference for external fire performance of roofs in the UK (Scotland still refers to both). This classification still covers External Fire Penetration and Spread of Flame of roof systems in their response to fire from outside the building, not to be confused with individual comprising components tested for reaction to fire to BS EN 13501-1. The test is not concerned with the behaviour of roofs when subjected to the effects of fire from the underside, i.e. from within the building.

## EUROPEAN FIRE STANDARDS

To advance and clarify the fire standards across Europe for External Fire Performance, the roofing industry has been going through a changeover from the test and classification of BS 476-3:2004 to the tests of TS 1187 (planned to become BS EN 1187 in the next few years) and classification using BS EN 13501-5, the culmination of which has now come in the new AD B 2019 edition. The standardisation into one European test proved indefinable as many countries within the EU had differing regulations and so four test standards were required to cover the legislation in place within the various member states at the time. As such, the TS 1187 has four tests for roof covering systems: t1 for Germany, t2 for Scandinavia, t3 for France and t4 for the UK (and used in the Republic of Ireland). The results from testing under TS 1187 with BS EN 13501-5 classification are given as European Class ratings  $B_{ROOF}(t4)$ ,  $C_{ROOF}(t4)$ ,  $D_{ROOF}(t4)$ ,  $E_{ROOF}(t4)$  and  $F_{ROOF}(t4)$ .

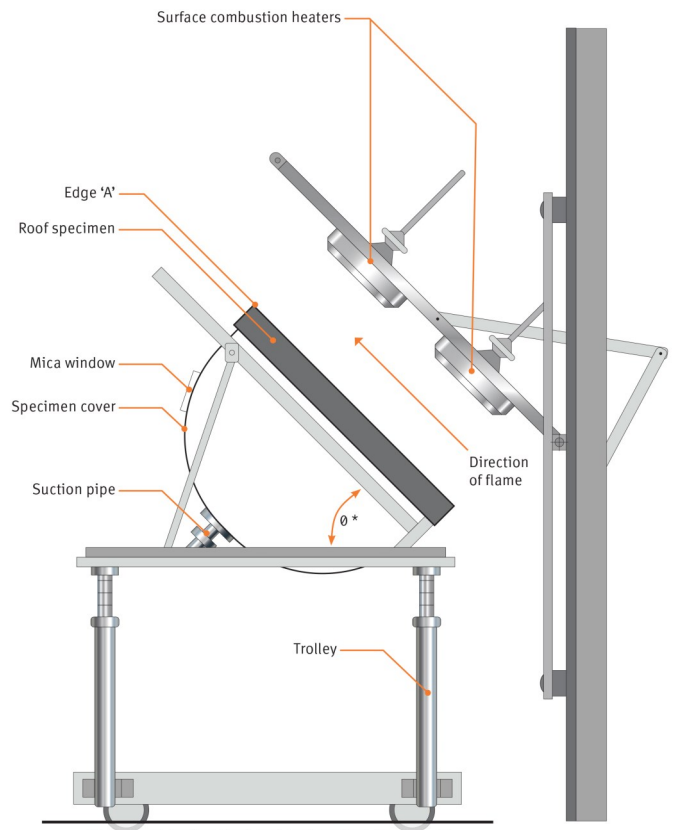

\* Angle  $\theta = 45^\circ$  for inclined test  
 $\theta = 0^\circ$  for horizontal test

The easiest way of explaining how these class ratings are achieved is to relate back to the BS 476-3 classification system. For TS 1187 Test 4 it was recognised that Approved Document B focused upon saving human lives rather than protecting the building itself and therefore as previously set to BS476-3, the highest requirement was A for Penetration - not penetrated within one hour, and C for Spread of Flame - more than 533mm. This meant that Test 4 needed to replicate the penetration test, but did not require the spread of flame full test because the preliminary test allowed the tester to determine if classification D or better was achieved. If the preliminary test specimen did not burn for more than ... (cont)

NATIONAL CLASS	EUROPEAN CLASS	MINIMUM DISTANCE FROM ANY POINT ON RELEVANT BOUNDARY (ENGLAND)	MINIMUM DISTANCE FROM ANY POINT ON RELEVANT BOUNDARY (SCOTLAND)
AA, AB or AC	$B_{ROOF}(t4)$	Unrestricted and can be used anywhere on the roof	Low Vulnerability (<6m)
BA, BB or BC	$C_{ROOF}(t4)$	At least 6m of the boundary	Medium Vulnerability (6-24m)
CA, CB or CC	$D_{ROOF}(t4)$	At least 6,12 or 20m of the boundary depending on the building type and use	Medium Vulnerability (6-24m)
AD, BD or CD	$E_{ROOF}(t4)$	At least 6,12 or 20m of the boundary depending on the building type and use	High Vulnerability (>24m)
DA, DB, DC or DD	$F_{ROOF}(t4)$	At least 20m of the boundary depending on the building type and use	High Vulnerability (>24m)

# Approved Document B - June 2022 amendments

five minutes after removal of the test flame, and spread of flame was not more than 381mm, then class C is achieved. That is why Test 4 just requires the preliminary test and penetration test, whilst still meeting the requirement of AD B.

## First Letter - Fire Penetration Classification (BS476-3)

A: Those specimens which have not been penetrated within one hour.

B: Those specimens which are penetrated in not less than 30 minutes.

C: Those specimens which are penetrated in less than 30 minutes.

D: Those specimens which are penetrated in the preliminary flame test.

## Second Letter - Spread of Flame Classification (BS476-3)

A: Those specimens on which there is no spread of flame.

B: Those specimens on which there is not more than 533mm, spread of flame.

C: Those specimens on which there is more than 533mm, spread of flame.

D: Those specimens which continue to burn for five minutes after the removal of the test flame or with spread of flame more than 381mm, in the preliminary test.

It should also be recognised that the classification is for all types of roof system, but with virtually all commonly used flat roof build-ups the aim is to achieve  $B_{ROOF}(t_4)$  when tested. This is why it is often forgotten that the classification is required to determine how close the roof is to the boundary and therefore adjacent buildings. The advantage of using systems achieving  $B_{ROOF}(t_4)$  is that there is no minimum distance required between adjacent buildings and this result is often referred to as 'unrestricted' or in Scotland 'low vulnerability'. The worse the external fire classification the further away any adjacent buildings need to be as shown in the table.

However, to meet the Building Regulations for fire you need to prove that the 'as installed' system has a valid test certificate. For this reason, late product substitution has a risk of not complying with the Building Regulations as there are hundreds of system permutations and so less common build-ups are

unlikely to have been tested. With the aim of reducing the number of permutations safely, the Flat Roofing Industry trade bodies (SPRA, LRWA & NFRC) working with BRE and Warrington Fire, have established through fire testing that testing on timber decking is the worst case scenario, thus in many scenarios removing the need for testing on steel or concrete decks. See NFRC/SPRA/LRWA 'Guidance Document—External Fire Exposure of Roof Decks within a Roof Build-Up'.

In roofs that incorporate non-combustible surface finishes as set out in European Commission Directive 2000/553/EC such as, minimum 50mm thickness of stone ballast; or minimum 40mm thick stone; or concrete paving slabs; or minimum 30mm thick sand and cement screed that fully cover the roof, these are deemed to fully satisfy the regulations to  $B_{ROOF}(t_4)$  with no testing. The national designations in the previous Approved Document B in Appendix A Table A5 for 'Flat roofs covered with bitumen felt' have been removed which means reinforced bitumen membranes with bitumen-bedded chippings or non-combustible tiles on the surface, if used, do now need to be tested.

## GREEN ROOFS

Approved Document B references 'Fire Performance of Green Roofs and Walls' published by the former Department of Communities and Local Government (DCLG) in 2013 and this document is the basis of the Green Roof Organisation (GRO) "Fire Risk Guidance Document". In summary, the growing medium should be a minimum 80mm thick, certified for use on green roofs and, where there is no permanent irrigation, organic content should be less than 50% and peat-free (Bauder Growing Medium organic content is less than 20% and peat-free). Fire Breaks 300mm wide should be a minimum of 50mm thick 20-40mm rounded pebbles; or a minimum of 40mm thick concrete; or stone paving slabs around all perimeters and 500mm wide if adjacent to an opening window, rooflight or similar that could allow fire to enter the building, with a 1m wide Fire Break across the roof every 40m. Maintenance is very important to prevent vegetation growing over Fire Breaks and to remove wildflower dry thatch in the Autumn.

The other route for demonstrating compliance is to have certified  $B_{ROOF}(t_4)$  through testing (e.g. Bauder sedum blankets XF301 and SB both achieve  $B_{ROOF}(t_4)$  on Bauder reinforced bitumen systems), although this is often difficult for some green roof build-ups due to the limitation of the test apparatus.

# Approved Document B - June 2022 amendments

NHBC follows this guidance but also has its own additional guidance for escape routes in landscaped roofs which it describes as “Protected Walkways” to give pedestrians protection from fire on an adjacent area. They should be a minimum of 1.8m wide and the roof build-up, including walkway finish, should achieve  $B_{ROOF}(t_4)$  or is “classified without further test” (CWFT) as  $B_{ROOF}(t_4)$ . However, any void formed under the “Protected Walkways” should be filled with a suitable granular fill e.g. 20-40mm stones, whilst maintaining drainage across the roof.

## ROOF INSULATION FIRE PERFORMANCE

Before the latest amendments to AD B, the key fire consideration for flat roofing was Requirement B4 which covered the resistance to fire from the outside of a roof system, where achieving F.AC (to BS476-3) in the past and now  $B_{ROOF}(t_4)$ , gave unrestricted distance to the boundary of the building. There had previously never been a limitation on the reaction to fire of any component of that roof build-up. It could be argued that there still is no limitation on Reaction to Fire if you accept that a balcony is not a roof, because all the common flat roof waterproofing membranes achieve no better than Class E and changing the insulation will not typically affect the  $B_{ROOF}(t_4)$  classification for the system. The one exception is for Compartmentation – covered in the next section.

Individual construction products are covered within BS EN 13501-1 for which insulation as a separate component will be encompassed and allocated a Class according to their reaction to fire test results with letter classifications from ‘A1’ through to ‘F’. On the whole, materials manufactured in whole or in part from plastics will achieve an ‘E’ rating, which will include for inverted roofs the insulants Expanded Polystyrene (EPS), Extruded Polystyrene (XPS) and for Warm Roofs - Polyisocyanurate (PIR).

Non-combustible insulants, such as cellular glass (BauderGLAS) along with mineral wool (BauderROCK), are clearly desirable materials to include in a flat roof specification because of fire performance, and it is important to consider and balance the factors for inclusion within a roof system. In general, non-combustible insulants are not as thermally efficient as PIR insulation and therefore extra thicknesses, increased weight and reduced compressive strength can be a limitation in some applications. PIR has the benefit of being highly thermally efficient, which reduces the

height and weight of a roof covering build-up whilst also offering good compressive strength meaning greater versatility on a project. PIR is also a thermoset, not a thermoplastic, which means that it does not melt but instead slowly carbonises to form a char at higher temperatures and retains its integrity due to its crosslinked structure. Within a Bauder warm roof waterproofing system the insulation, be it mineral wool, cellular glass, or PIR, is not directly exposed and the roof external fire performance is therefore determined by the performance of the waterproofing and the roof acting as a whole system; thus, these insulants in situ all conform to Building Regulations for External Fire on Roofs in the same way—not one achieving a higher rating than the other, whilst all potentially able to achieve  $B_{ROOF}(t_4)$ .

Select grades of Bauder PIR insulation have also been tested and approved by fire experts FM Approvals, whose parent company’s (FM Global) principal global business is the insurance of buildings and loss prevention. When tested to meet the performance limits of FM Approvals standard 4470, FM Approvals recognises the performance of defined PIR insulation and mineral wool insulation in a similar manner, so long as they are installed as part of a recognised FM Approved Assembly, i.e. a stated system configuration listed on FM Approvals’ up-to-date online database, ‘RoofNav’. Bauder PIR, as with all other products that are FM Approved, are under regular surveillance by FM Approvals to confirm the consistency of production.

With the exception of a balcony, where if on a “Relevant Building” and if insulated it will need to be non-combustible BauderGLAS, inverted roof constructions also generally use plastic-based insulants such as EPS and XPS, though these are only used when they are fully covered with paving slabs, stones, etc and are therefore often deemed to meet Building Regulations without testing (CWFT as defined in European Commission Directive 2000/553/EC).

## COMPARTMENTATION – JUNCTION OF COMPARTMENT WALL WITH ROOF

Under the heading “Compartmentation” in AD B Requirement B3: Internal fire spread (structure) there is a lack of clarity regarding “junction of compartment wall with roof”, which has led to a degree of disagreement and misinterpretation. Flat roofs are not treated as “elements of structure” and therefore there are no special precautions (unless they serve the function of a

# Approved Document B - June 2022 amendments

floor e.g. a roof terrace). However, there are possibly some precautions required for a flat roof passing over the junction with a wall, and it is this that divides opinion. Department for Levelling Up, Housing and Communities (DLUHC) acknowledge the issue and have started on a programme of work to clarify the requirement at this wall/roof junction, the outcome is anticipated 2023.

The current wording states that to reduce the risk of fire spreading over a flat roof from one compartment to another, a 1500mm wide zone of the roof, either side of the wall, should have both a “roof covering” classified as  $B_{ROOF}(t_4)$  and a substrate or deck of a material rated Class A2-s3, d2 or better e.g. concrete or steel. However, there is a Special Application for Purpose Groups - Residential (dwellings), Residential (other), Office or Assembly and Recreation - where if the roof is not more than 15m high it allows materials rated Class B-s3, d2 or worse, e.g. timber or plywood, as a deck to the roof covering.

In practice this means that flat roofs achieving  $B_{ROOF}(t_4)$  that are on a concrete or metal deck will comply with the general requirement. Flat roofs achieving  $B_{ROOF}(t_4)$  that are on a timber deck will meet the Special Application requirement provided the roof is less than 15m high and on a residential, office or assembly and recreation building. If the flat roof is not in one of these three Purpose Groups or is above 15m in height, the roof deck will need to be changed to a suitable\* non-combustible material for 1500mm either side of the wall.

The issue in dispute is the statement “Fire-stopping to be carried up to the underside of the roof covering” and whether “roof covering” means just the waterproofing or if it also includes the insulation and AVCL, as would be included in a full roof system as tested to TS1187 Test 4. If it is accepted that the “roof covering” does not include the insulation and AVCL then using non-combustible insulation would be required, although finding a non-combustible AVCL for flat roof application maybe difficult for some systems. It is further complicated by the guidance trying to cover both pitched and flat roofs together and this brings debate about if the “substrate or deck” should be non-combustible? In flat roofing it is common to use the term “deck”, but this does not always work for pitched roofing and therefore “substrate” is the more appropriate term, but if you apply the term “substrate” to a flat roof some may then interpret that everything below the “roof covering” must be non-combustible. This contradicts the reliance on

$B_{ROOF}(t_4)$  in this section which is a system test and not a component test. The deck and roof build-up make the whole system –  $B_{ROOF}(t_4)$  is not relevant just the “roof covering”. Another consideration is there is not currently available a non-combustible AVCL suitable for use in all types of flat roof systems. All of this therefore brings into question the interpretation of “substrate” and “roof covering”. There is an alternative, which is to extend the wall up through the roof by at least 375mm to meet the requirement, if the roof covering either side of the wall is classified as  $B_{ROOF}(t_4)$  then the wall may be reduced to 200mm.

## Adaption of diagram 5.2a, Approved Document B

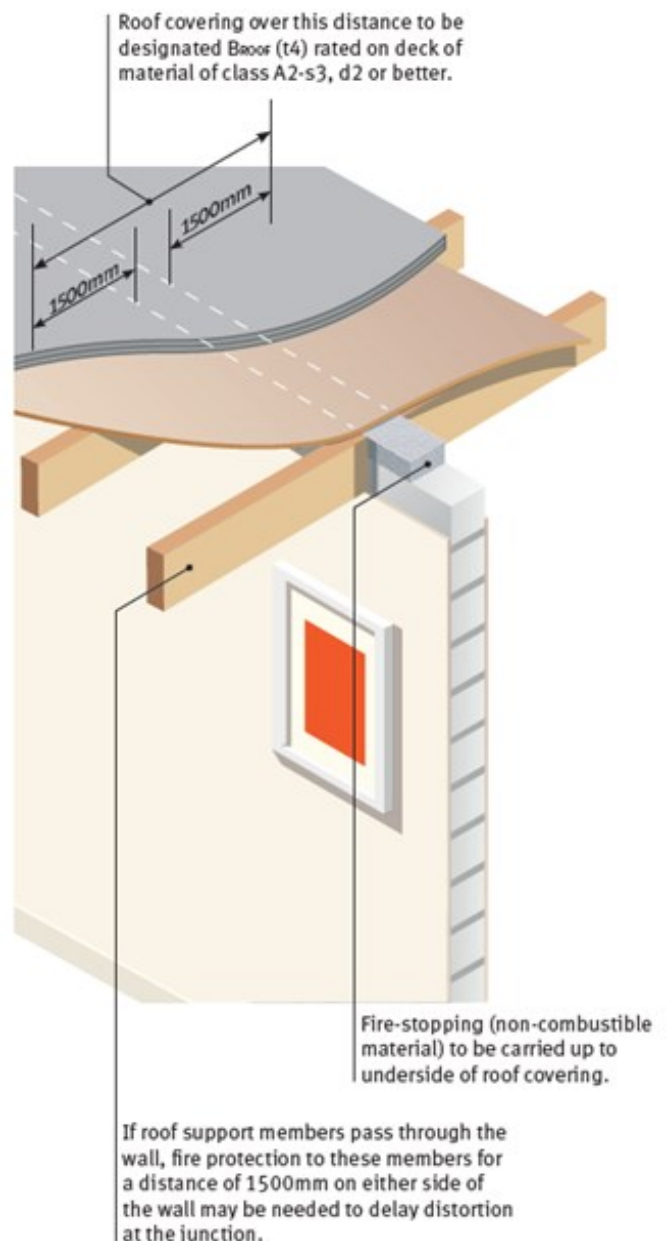

\* Many non-combustible deck materials are not suitable as flat roof decks. See SPRA/LRWA/NFRC “Guidance for the use of Building Boards with A1 or A2 Reaction to Fire Classifications in Flat Roofing.”



# Approved Document B - June 2022 amendments

## NEW REQUIREMENTS OF APPROVED DOCUMENT B – EXTERNAL WALLS AND 'SPECIFIED ATTACHMENT'

In late 2018 Approved Document B was amended to incorporate in Requirement B4 Regulation 7 - the Government requirement to ban combustible materials as part of the external wall in buildings containing one or more dwellings or an institution. In June 2022, Approved Document B had a further enhancement, mainly in response to the public consultation in 2020, these “Relevant Buildings” include student accommodation, care homes, sheltered housing, hospitals, school dormitories, and newly added were hotels, hostels and boarding houses in buildings where there is a storey at least 18m above ground level. It should be noted that in response to the Public Consultation, the applicable height for balconies for Purpose Groups 1 and 2 (residential) has been reduced to 11m (Cl.10.10 Vol1 and Cl.12.11 Vol2) along with the extended scope of “Relevant Buildings”. Regulation 7 also introduced a new term “Specified Attachment” (defined in Regulation 2) which was included in the ban of combustible materials along with parts of an external wall. The definition includes a balcony 'attached' to an external wall. Notable exclusions to the ban are membranes, thermal break materials, any part of a roof (except habited mansards with a slope greater than 70°) and added in 2022, the top layer of the balcony floor if it achieves A2fl-s1 or better, provided it is over an impermeate substrate.

This new term “Specified Attachment” has caused much misunderstanding with the definition of a balcony, and it appears to contradict the European Commission Directive 2000/553/EC and Regulation 7(3) if the

definition of a balcony is deemed to include an insulated roof. The flat roofing industry has worked with the NHBC to come to a common understanding which also mirrors the new BS 8579:2020 “Guide to the Design of Balconies and Terraces”. Attached balconies are differentiated from roof terraces in that they are not over habited conditioned spaces and are usually bolted to, or cantilevering from, the external wall. This also includes most inset balconies. So for the purposes of Approved Document B, balconies are not deemed to be roofs.

For areas established correctly as balconies – “Specified Attachment” on “Relevant Buildings”, Regulation 7(2) states that non-combustible materials should be used. However, the waterproofing membrane is excluded from this by Regulation 7(3)(g). Further, on AD B B4 Additional Considerations section, contrary to many interpretations, in the first sentence of a) for “membranes”, it does not mention or include for “Specified Attachments” and refers to “ground level”, therefore it is not relevant to membrane roofs or balconies.

There is another issue that has been highlighted by the new AD B that has existed for years and now needs to be clarified – “When is a wall a roof?”. The area at issue is where the flat roof waterproofing abuts a perimeter or roof penetration and is traditionally dressed a minimum 150mm above the finished roof level/walking surface (as set out in BS 6229).

### BS 8579:2020

#### Extract from the design guide

- |   |   |
|---|---|
| <ul style="list-style-type: none"> <li>1 Projecting enclosed balcony</li> <li>2 Projecting open balcony</li> <li>3 Recessed open balcony</li> <li>4 Recessed enclosed balcony</li> <li>5 Juliet guarding</li> <li>6 Freestanding balcony</li> </ul> | <p><b>Areas required to achieve fire performance B<sub>ROOF</sub>(t4)</b></p> <ul style="list-style-type: none"> <li>7 Access balcony</li> <li>8 Terrace</li> <li>9 Access terrace</li> <li>10 Recessed open terrace</li> <li>11 Recessed enclosed terrace</li> </ul> |
|---|---|

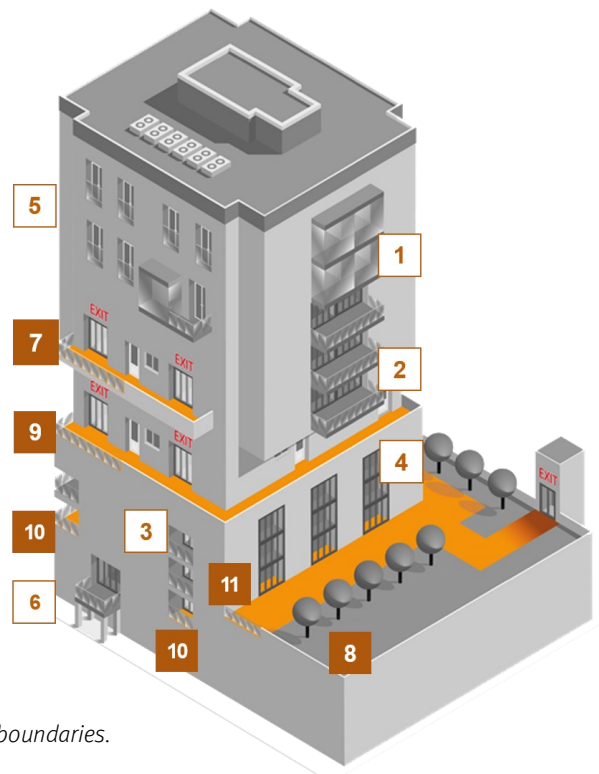

NOTE: National regulations might cover roof performance in relation to relevant boundaries.

*relation to relevant boundaries.*

# Approved Document B - June 2022 amendments

In changes made in 2022 to the second sentence of a) of the Additional Considerations clause an attempt to further clarify that ‘roofing’ membranes can also be used to connect to an external wall is included, but it adds confusion by stating they ‘do not need to achieve a minimum of Class A2-s1,do’. The exception for membranes exists because if they are to be used in flat roof waterproofing the Reaction to Fire is typically class E.

The definition of a roof is 0-70 degrees and above this it is a wall, yet 7(3) excludes any part of a roof connected to an external wall. In a letter from the Ministry of Housing, Communities and Local Government (MHCLG) to the Flat Roofing Industry (in November 2019) it was acknowledged that the part of the roof dressed up the wall is exempt but with no clarification on the extent i.e. max height. Again, the Flat Roofing Industry working with the NHBC have developed some guidelines which also deal with the supplemental queries about the insulation often used at these points. Insulation on the face of the wall/abutment is usually a thermal break and subsequently exempt from the ban. Therefore, for the area up to 150mm above the finished roof level/walking surface, it can be combustible insulation provided that it is no thicker than 60mm (deemed sufficient thickness for a thermal break) and does not span across a compartment line. For heights above this, the insulation is recommended to be non-combustible and, for the NHBC - whilst acknowledging that this would be a wall, typically limited to approximately 1100mm for parapets and lift/stair overruns.

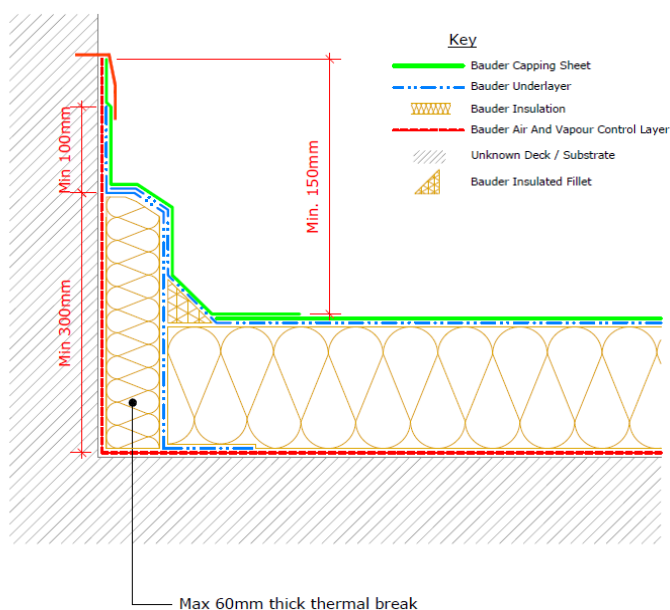

Thermal Break—Wall Flashing Detail for Bituminous Systems

## BAUDER WATERPROOFING SYSTEMS

Bauder tested exposed membrane waterproofing systems can achieve the highest classification for external fire testing in compliance with the guidance in Approved Document B and are typically classed as 'unrestricted' or 'low vulnerability'.

Bauder has a continuous fire testing programme where the most common Bauder system build-ups have been recently tested, including thick and thin insulation, which means that all thicknesses in between are covered in the same approval to give the most complete cover for certification. Having only one test thickness of insulation is only valid for that thickness and no other because variance in thicknesses can change the test result, just as using generic insulation types is not acceptable as there can be differences due to the core or facings - 'as built' should match 'as tested'. Our BBA certification for fire testing was up to date at publication, but results have been extended by our continuous testing, so check with the Bauder technical department for the latest status if you do not find the required test result.

Bauder ballasted membrane waterproofing systems generally achieve compliance with Approved Document B due to the European Commission Directive 2000/553/EC “classification without further testing” (CWFT) rules; or the DCLG document “Fire Performance of Green Walls and Roofs”; or a combination of these and including the exposed membrane testing.

This guidance document is principally about the English situation based upon Approved Document B, but the Welsh Part B substantially follows that of the English one and, as yet, there has been no change of the Northern Ireland Technical Booklet E. There are more notable differences with the Scottish Section 2 requirements, some of which have been noted in this guidance.

To ensure our guidance is current, Bauder has participated in the relevant BSI Technical Committees on roof fire testing and the guide to design of balconies and terraces; has been in proactive dialogue with DLUHC on AD B; and has worked collaboratively with the NHBC to agree common guidelines. If there is some area covered in this document that you require more guidance with, please do not hesitate to ask as it is an ever-evolving topic.



# Approved Document B - June 2022 amendments

## SUMMARY

- Bauder waterproofing systems are tested to TS 1187 Test 4.
- Bauder tested exposed roof membrane waterproofing systems can achieve the highest classification for external fire testing in compliance with Approved Document B 2019 and are typically classified as 'unrestricted' or 'low vulnerability'.
- Bauder ballasted membrane waterproofing systems generally achieve compliance with Approved Document B without testing.
- 'As built' should match 'as tested'.
- A balcony is not a roof for the purpose of Approved Document B.
- The roof/wall thermal break is excluded from the ban.
- If in doubt, it is recommended to consult with the appropriate Building Control body for the project.

**UNITED KINGDOM**

Bauder Limited  
70 Landseer Road, Ipswich, Suffolk  
IP3 0DH, England  
T: +44 (0)1473 257671  
E: info@bauder.co.uk  
[bauder.co.uk](http://bauder.co.uk)

**IRELAND**

Bauder Limited  
O'Duffy Centre, Carrickmacross,  
Co. Monaghan, Ireland  
T: +353 (0)42 9692 333  
E: info@bauder.ie  
[bauder.ie](http://bauder.ie)

**Respecting the planet**

**Reducing the use of materials**



This report is only available in digital format to reduce the use of paper. If you need to print it, please recycle at the end of purposeful use.